

所有物质均符合环保要求

东莞市溪榜电子有限公司  
受控文件

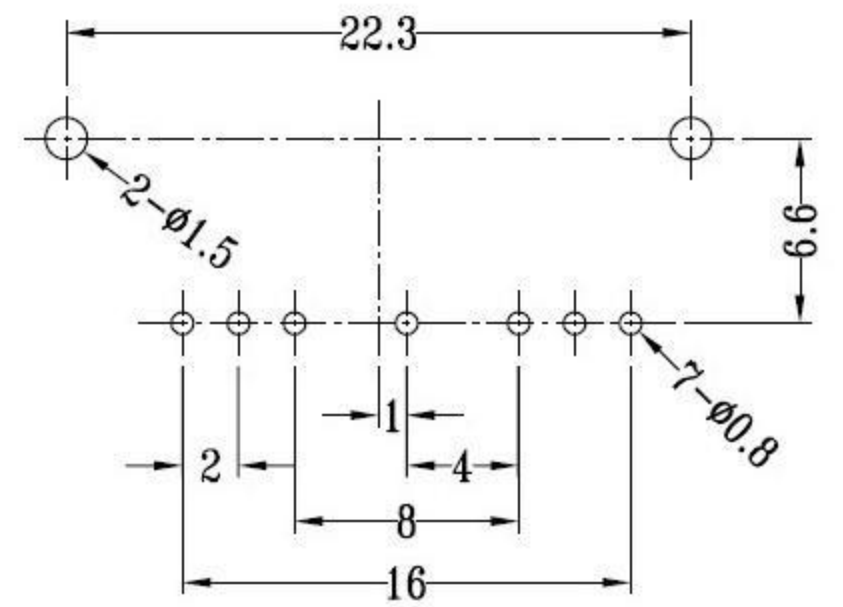
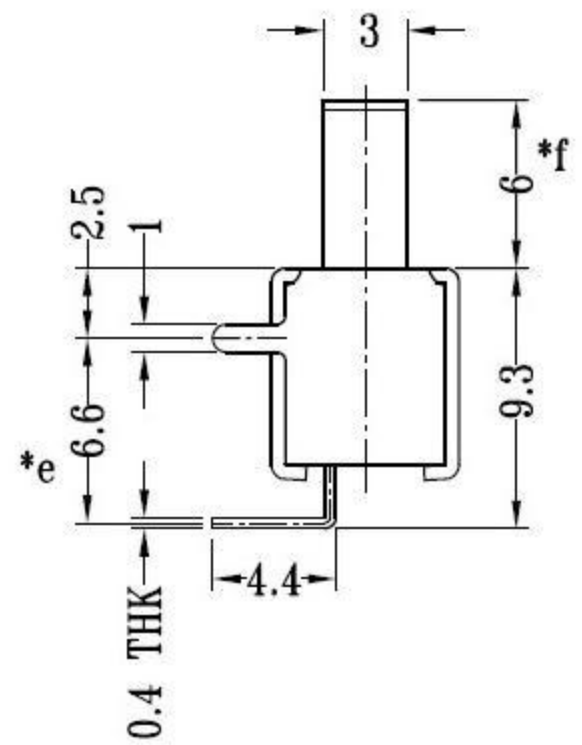
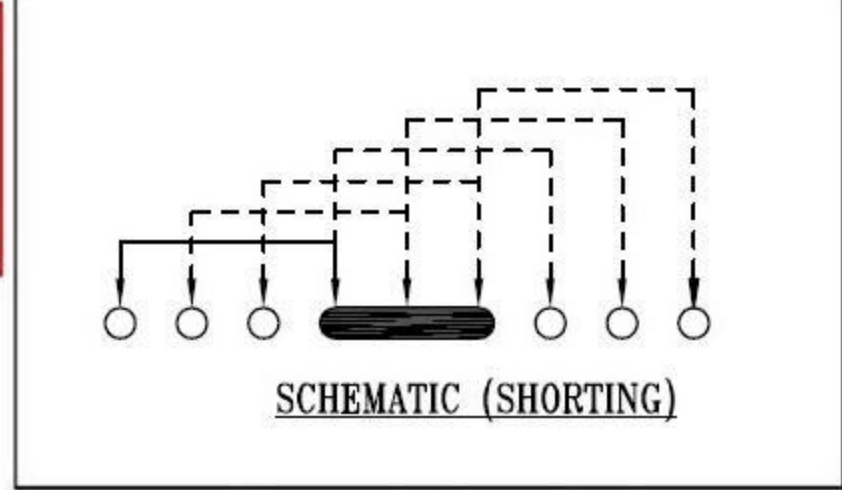
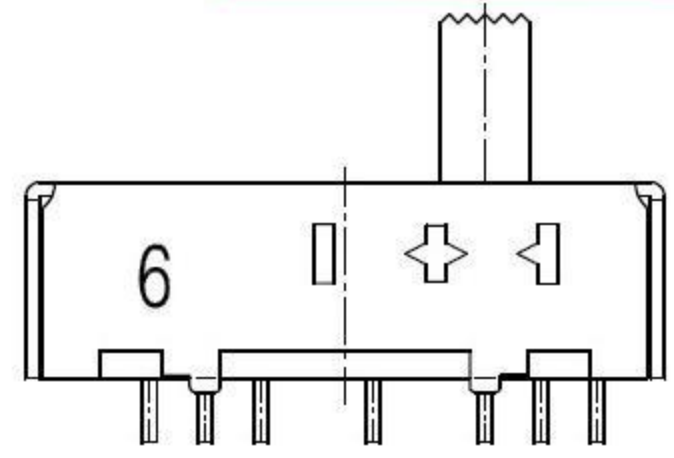
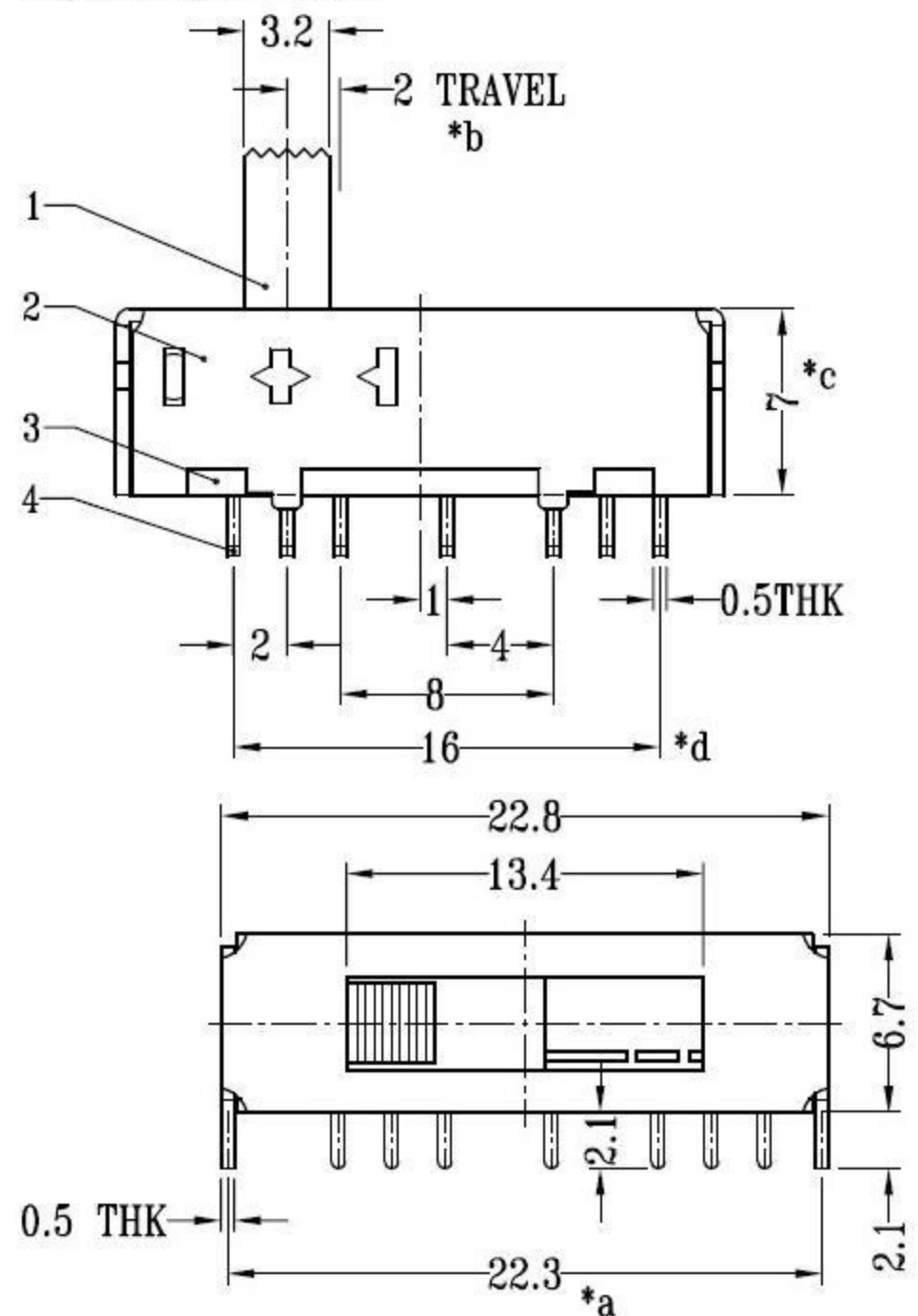

P.C.B LAYOUT  
BOTTOM VIEW

手柄X位置, 与操作力按照用户需求定制!

NO.	PARTS	MATERIALS	Q'TY	FINISH	TOLERANCE UNLESS SPECIFIED		ISSUE DATE		DESCRIPTIONS OF REVISION		APPD.
8					WITHIN	A	2010-01-02	初版			
7	STEEL BALL	STEEL	2	NATURAL	OVER	ISSUE	DATE				
6	SPRING	STEEL WIRE	1	NATURAL	TITLE : SLIDE SWITCH			UNIT : mm	DRWG NO.:		
5	CONTACT CLIP	PBS STRIP	2	Ag PLATED	MODEL:			SCALE: 2:1	DWN.	2010-01-02	
4	TERMINAL	BRASS STRIP	8	Ag PLATED	东莞市高迪电子有限公司			CHK'D		2010-01-02	
3	BASE	PHENOLIC RESIN	1	NATURAL				APPD.		2010-01-02	
2	FRAME	STEEL STRIP	1	Ni PLATED							
1	KNOB	POM	1	BLACK							